

# C540



AUSTRALIAN MADE. WORLD'S BEST.



# AUSTRALIAN MADE. WORLD'S BEST.

**WE KNOW BUSINESSES THAT TRANSPORT GOODS ARE AS VITAL TO AUSTRALIA'S ECONOMY AS THOSE THAT GROW, MINE OR MANUFACTURE THEM.**

**SO WE MAKE IT OUR BUSINESS TO BUILD THEM THE WORLD'S BEST TRUCKS.**

We have some of the most demanding road conditions in the world, with many trucks in Australia travelling vast distances on corrugated roads, through billowing dust and extreme heat and humidity. From the saleyards, the forests, and the remotest of mines, to the ports, farmyards and cities, Australian trucks can haul more than three times heavier loads than trucks in other parts of the world.

To meet these challenges a truck needs to be purpose-built and tough enough to stand the test of time, while providing operators with a safe and comfortable environment. Every Australian Kenworth is designed and manufactured for its intended task and to individual customer requirements. Manufactured with uncompromising quality, Kenworths work harder for longer, offering strength, durability and reliability.

To be Australian Made. World's Best, we cover millions of kilometres in challenging conditions. We test the chassis, cooling, brakes and suspension and every other component to the limit, so each truck meets our strict quality guidelines and the needs of our customers.

Designed and manufactured in the Melbourne suburb of Bayswater since 1971, supported by PACCAR's global strength and services, and with the backing of an extensive dealer network throughout Australia, New Zealand and Papua New Guinea, we have you covered.

**KENWORTH, DELIVERING THE RIGHT TRUCK FOR YOU AND YOUR ENVIRONMENT.**



**TAILORED  
TO SUIT  
YOUR NEEDS**

# TOUGH MINING RESOURCE



## PRECIOUS METAL FOR THE MINING INDUSTRY

With a requirement to meet the demands of off-highway operators in the mining sector, Kenworth has designed and manufactured its biggest ever prime mover – the C540. A truck capable of handling extreme heavy-duty workloads in the harshest of operating conditions.

The C540 mining truck, in conjunction with powered trailers, has the capacity to gross 500 tonnes; the power to pull up a six to eight per cent gradient; the gearing to cruise at 70 kph for distances up to 100 kilometres on the flat, and the durability to do it all day, every day.



**C540**

# OFF-HIGHWAY RELIABILITY



[WWW.KENWORTH.COM.AU/TRUCKS/C5-SERIES/C540](http://WWW.KENWORTH.COM.AU/TRUCKS/C5-SERIES/C540)



## STRENGTH DURABILITY RELIABILITY



### SITE SPECIFIC

The C540 is available in one basic arrangement: 3.3m wide for use on mine haul roads. Drive axle ratio and engine ratings options allow the C540 to be configured to suit specific haul tasks.

As each Kenworth C540 is custom engineered, within the range of optional equipment, specific vehicle characteristics vary. The operational variables due to site condition, route profile and duty cycle factors all influence the detailed specifications and operation weights.

### SUPREME DRIVER COMFORT

The C540 cab is ergonomically designed, roomy and easily maintained. Heavy duty closed cell insulation minimises road noise throughout the cab and all controls, switches and instruments fall easily to hand or eye, optimising driver concentration and minimising fatigue. With a high level of standard equipment and extensive options, the best in driver performance is comfortably achieved. A 'data pod' at the rear of the cab provides extra space for modern telematics.

### DRIVELINE DYNAMICS

The C540 has been developed from the successful and durable C510 platform to accommodate the Cummins QSK19 LTA series 19 litre engine installed with the Allison H6610 6 speed automatic transmission. The drive train package provides performance and durability, primarily in heavy haul mine road train applications. The QSK19 LTA engine uses separate cores for the engine water jacket and the air-to-water aftercooler. This dual radiator combination significantly increases the airflow required for cooling.

The transmission has its own cooling package, similar in design to the main engine system, located at the rear of the cab to dissipate the transmission torque convertor or retarder heat loads. The transmission has the ability to cope with the requirement for maximum torque fast changes on the up grades, extended hydraulic retarder braking on the down grades and cruising on the flat.

# C540 MAIN SPECIFICATIONS

# KENWORTH SUPPORT

<b>ENGINE</b>	CUMMINS QSK19 LITRE 650 LTA PRODUCING 650 HP AND 2275 LB-FT TORQUE
<b>TRANSMISSION</b>	MID-MOUNTED ALLISON H6610 6 SPEED AUTOMATIC WITH SEPARATE COOLING SYSTEM AND RETARDER
<b>STEER AXLE</b>	DANA EFA24 10 TONNE CAPACITY
<b>DRIVE AXLE</b>	AXLETECH SPRC 2197 50 TONNE CAPACITY
<b>REAR SUSPENSION</b>	HENDRICKSON R1000
<b>TYRES</b>	MICHELIN 385/95R25
<b>RIMS</b>	TITAN 10 X 25
<b>ROPS/FOPS</b>	ALL INDUSTRIES GROUP

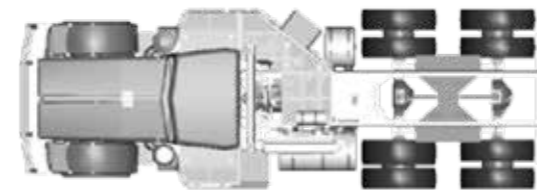
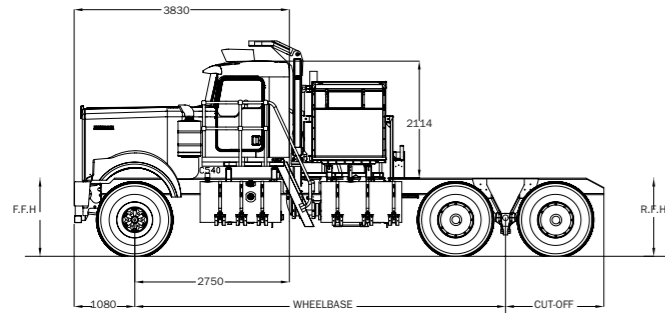

#### IMPORTANT NOTES

All frame height dimensions are to the top of the frame using 295mm rails.

For illustration purposes different configurations have been used.

Variations will occur due to tare weight differences caused by optional equipment and fuel. Variations of +/- 25mm can be expected on heavy duty trucks.

Heights have been calculated with the tyre in an unladen condition and unless specified Bridgestone tyres have been used in the calculations. Variations will be caused by different tyre manufacturers.

For a wide range of options, contact your Kenworth Dealer.

#### Front Frame Height (F.F.H.) mm - Unladen

	Tyres
Front Spring	385/95 R25 XMH
10T Taper	1410

#### Rear Frame Height (F.F.H.) mm - Unladen

	Tyres
Rear suspension	385/95 R25 XMH
Hendrickson R1000	1360

\*C540 - 295mm frame rail



PACCAR Inc. is a Six Sigma company and global technology leader in the design, manufacture and customer support of high-quality light, medium, and heavy-duty trucks under the Kenworth, Peterbilt and DAF brands. PACCAR also designs and manufactures advanced diesel engines, provides financial services and information technology, and distributes truck parts related to its principal business.



The PACCAR dealer network for Kenworth and DAF trucks is one of the strongest in Australia, comprising factory-trained, experienced technicians who have access to modern facilities, diagnostic equipment and specialist tooling. Offering a wide range of services from truck cleaning to total overhauls, your local Kenworth and DAF dealership has the specialist equipment, skills and expertise to look after you and your truck.



The right financing can be as important to your success as the right truck and PACCAR Financial is dedicated solely to the trucking industry. With more than 35 years' experience in the Australian transport industry they understand today's business and continue to support with innovative loan and lease options. Talk to PACCAR Financial about a financial solution to meet your needs.

[www.paccarfinancial.com.au](http://www.paccarfinancial.com.au)



PACCAR Parts offers an extensive range of parts and accessories for all your truck servicing needs. The national distribution centres in Melbourne and Brisbane are amongst the most modern and efficient in Australia and use advanced RF technology in supplying the PACCAR Dealer Network. With an inventory of more than 46,000 PACCAR and vendor-branded parts, they have the parts you need, when you need them.

[www.paccarparts.com.au](http://www.paccarparts.com.au)



As well as ISO 14001:2015, which sets the framework and criteria for an environmental management system, PACCAR Australia and Kenworth Trucks are certified ISO9001:2008, which sets the framework for a Quality Management System, and PACCAR Australia is certified OHSAS18001:2007, an international standard, which enables an organisation to improve its performance by having control over, and knowledge of, all relevant hazards resulting from normal operations and abnormal situations.



AUSTRALIAN MADE. WORLD'S BEST.

# AUSTRALIA'S BEST DEALER NETWORK



PACCAR Australia Pty Ltd,  
64 Canterbury Road,  
Bayswater, Victoria 3153

Phone (03) 9721 1500

Find us at:  

## IF A TRUCK'S NOT ON THE ROAD...IF IT'S NOT RUNNING... THEN IT'S NOT DOING ITS JOB

So in addition to making the nation's most heavy-duty truck, we built the country's most comprehensive service and support network.

Comprising more than 50 regional and metropolitan locations, Kenworth has built an extensive truck dealer network across Australia, New Zealand and Papua New Guinea that is renowned for its professionalism and excellence in the heavy duty truck industry.

For more information contact your local  
Kenworth Dealer or go to [www.kenworth.com.au](http://www.kenworth.com.au)



**IMPORTANT:** The vehicles shown in this brochure are for illustrative purposes only and may include some non-standard optional equipment. All weights and measurements should be regarded as approximate only. For full details contact your Kenworth Dealer. In the interests of product improvement, Kenworth reserves the right to change these specifications without prior notice.



AUSTRALIAN MADE. WORLD'S BEST.