

C510



AUSTRALIAN MADE. WORLD'S BEST.



AUSTRALIAN MADE. WORLD'S BEST.

WE KNOW BUSINESSES THAT TRANSPORT GOODS ARE AS VITAL TO AUSTRALIA'S ECONOMY AS THOSE THAT GROW, MINE OR MANUFACTURE THEM.

SO WE MAKE IT OUR BUSINESS TO BUILD THEM THE WORLD'S BEST TRUCKS.

We have some of the most demanding road conditions in the world, with many trucks in Australia travelling vast distances on corrugated roads, through billowing dust and extreme heat and humidity. From the saleyards, the forests, and the remotest of mines, to the ports, farmyards and cities, Australian trucks can haul more than three times heavier loads than trucks in other parts of the world.

To meet these challenges a truck needs to be purpose-built and tough enough to stand the test of time, while providing operators with a safe and comfortable environment. Every Australian Kenworth is designed and manufactured for its intended task and to individual customer requirements. Manufactured with uncompromising quality, Kenworths work harder for longer, offering strength, durability and reliability.

To be Australian Made. World's Best, we cover millions of kilometres in challenging conditions. We test the chassis, cooling, brakes and suspension and every other component to the limit, so each truck meets our strict quality guidelines and the needs of our customers.

Designed and manufactured in the Melbourne suburb of Bayswater since 1971, supported by PACCAR's global strength and services, and with the backing of an extensive dealer network throughout Australia, New Zealand and Papua New Guinea, we have you covered.

KENWORTH, DELIVERING THE RIGHT TRUCK FOR YOU AND YOUR ENVIRONMENT.



**TAILORED
TO SUIT
YOUR NEEDS**



DEPENDABLE STRENGTH



ONE TOUGH RESOURCE FOR MINING

Developed to meet the needs of mine haul operations, the C510 is an off-highway truck, incorporating a 19 litre engine (600 hp/1950 lb-ft of torque) with manual transmission and a cooling capacity, which comfortably exceeds the 50°C ambient temperatures experienced in the remote mines of Australia. A higher cab, larger radiator core and hydraulic fan drive are all part of this Australian designed package. It's The benchmark for all heavy-haul tractor units.

In true Kenworth tradition the C510 gets the job done in some of the harshest conditions the globe can deliver. Available in a 6x4 hub reduction tandem-drive or a 8x6 hub reduction tri-drive, the C510 is engineered and built using the best components – their strength, durability and reliability result in low maintenance costs and more time on the job.



C510

EXTREME HEAVY-DUTY PERFORMER

WWW.KENWORTH.COM.AU/TRUCKS/C5-SERIES/C510



STRENGTH DURABILITY RELIABILITY



SOLID CONSTRUCTION

Custom engineering allows each truck to be optioned to best suit its application. High tensile steel chassis rails offer a straight continuous channel and are custom detailed to suit your needs. Engineering steel, aluminium and fibreglass into one, the cab is one of the lightest and toughest cabs built and its riveted construction is easily repaired, with steel reinforcements in high stress areas.

Optimisation of drive train components enables higher durability and lower fuel consumption within the appropriate operating constraints.

SUPREME DRIVER COMFORT

In a C510, drivers can meet demanding performance levels with the highest standards of comfort. Kenworth cabs are ergonomically designed, roomy and easily maintained. Heavy duty closed cell insulation minimises road noise throughout the cab and all controls, switches and instruments fall easily to hand or eye, optimising driver concentration and minimising fatigue. With a high level of standard

equipment and extensive options, the best in driver performance is comfortably achieved.

SURE FOOTED AGILITY

Australian design and manufacturing, high quality materials and Kenworth's engineering expertise, place the Kenworth C5 Series trucks at the head of the field.

The front axle is set forward, with integral power steering mounted ahead allowing maximum steering angles, and better weight distribution, on or off-road. The agility and strength of the C510 has been demonstrated repeatedly throughout Australia in some of the toughest and most testing environments.



C510

C510 MAIN SPECIFICATIONS

KENWORTH SUPPORT

CONFIGURATION 6X4
ENGINE 600 LTA and 600 HP
TRANSMISSION EATON RTLO221918B
STEER AXLE MERITOR FL941
DRIVE AXLE AXLETECH SPRC2197
REAR SUSPENSION HENDRICKSON R1000
TYRES MICHELIN 385/95R25
RIMS TITAN 10 X 25

CONFIGURATION 8X6
ENGINE 600 LTA and 600 HP
TRANSMISSION EATON RTLO221918B
STEER AXLE MERITOR FL941
DRIVE AXLE SISU FR3P-48
REAR SUSPENSION NEWAY AD390/10
TYRES BRIDGESTONE 315/80 R22.5
RIMS TITAN 9.00 X 22.5

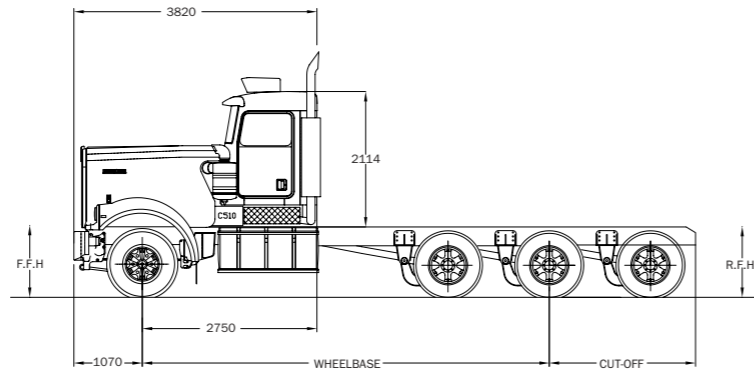
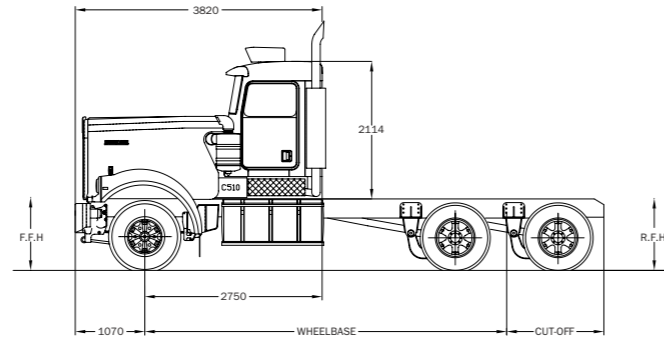

PACCAR Inc



PACCAR
FINANCIAL

PACCAR Inc. is a Six Sigma company and global technology leader in the design, manufacture and customer support of high-quality light, medium, and heavy-duty trucks under the Kenworth, Peterbilt and DAF brands. PACCAR also designs and manufactures advanced diesel engines, provides financial services and information technology, and distributes truck parts related to its principal business.

The PACCAR dealer network for Kenworth and DAF trucks is one of the strongest in Australia, comprising factory-trained, experienced technicians who have access to modern facilities, diagnostic equipment and specialist tooling. Offering a wide range of services from truck cleaning to total overhauls, your local Kenworth and DAF dealership has the specialist equipment, skills and expertise to look after you and your truck.

The right financing can be as important to your success as the right truck and PACCAR Financial is dedicated solely to the trucking industry. With more than 35 years' experience in the Australian transport industry they understand today's business and continue to support with innovative loan and lease options. Talk to PACCAR Financial about a financial solution to meet your needs.

www.paccarfinancial.com.au

Front Frame Height (F.F.H.) mm - Unladen

Front Spring	Tyres		
	315/80 R22.5 M857	385/65 R22.5 R249	385/95 R25 XMH
8.2T Slipper	1145	1148	1268
9.1T Slipper	1180	1183	1303

Rear Frame Height (R.F.H.) mm - Unladen

Rear Suspension	Tyres		
	295/80 R22.5 R150-II M857	315/80 R22.5 M857R249	385/95 R25 XMH
Neway AD369/10	1089	1093	N/A
Hendrickson R1000	N/A	N/A	1367

IMPORTANT NOTES

All frame height dimensions are to the top of the frame using 295mm rails.

For illustration purposes different configurations have been used.

Variations will occur due to tare weight differences caused by optional equipment and fuel. Variations of +/- 25mm can be expected on heavy duty trucks.

Heights have been calculated with the tyre in an unladen condition and unless specified Bridgestone tyres have been used in the calculations. Variations will be caused by different tyre manufacturers.

For a wide range of options, contact your Kenworth Dealer.

PACCAR
PARTS

PACCAR Parts offers an extensive range of parts and accessories for all your truck servicing needs. The national distribution centres in Melbourne and Brisbane are amongst the most modern and efficient in Australia and use advanced RF technology in supplying the PACCAR Dealer Network. With an inventory of more than 46,000 PACCAR and vendor-branded parts, they have the parts you need, when you need them.

www.paccarparts.com.au



As well as ISO 14001:2015, which sets the framework and criteria for an environmental management system, PACCAR Australia and Kenworth Trucks are certified ISO9001:2008, which sets the framework for a Quality Management System, and PACCAR Australia is certified OHSAS18001:2007, an international standard, which enables an organisation to improve its performance by having control over, and knowledge of, all relevant hazards resulting from normal operations and abnormal situations.

*C510 - 295mm frame rail



AUSTRALIAN MADE. WORLD'S BEST.

AUSTRALIA'S BEST DEALER NETWORK



PACCAR Australia Pty Ltd,
64 Canterbury Road,
Bayswater, Victoria 3153

Phone (03) 9721 1500

Find us at:



IF A TRUCK'S NOT ON THE ROAD...IF IT'S NOT RUNNING... THEN IT'S NOT DOING ITS JOB

So in addition to making the nation's most heavy-duty truck, we built the country's most comprehensive service and support network.

Comprising more than 50 regional and metropolitan locations, Kenworth has built an extensive truck dealer network across Australia, New Zealand and Papua New Guinea that is renowned for its professionalism and excellence in the heavy duty truck industry.

For more information contact your local
Kenworth Dealer or go to www.kenworth.com.au



IMPORTANT: The vehicles shown in this brochure are for illustrative purposes only and may include some non-standard optional equipment. All weights and measurements should be regarded as approximate only. For full details contact your Kenworth Dealer. In the interests of product improvement, Kenworth reserves the right to change these specifications without prior notice.



AUSTRALIAN MADE. WORLD'S BEST.