



C510

DEFINING TOMORROW

A decorative graphic consisting of three parallel lines that converge towards the bottom center of the page, creating a perspective effect.

AUSTRALIAN MADE. WORLD'S BEST.

THE KENWORTH C510

Developed to meet the specific needs of mine haul operations, the C510 incorporates a robust 19 litre engine, the Cummins QSK19, with cooling capacity comfortably exceeding the 50°C ambient temperatures commonly experienced in the remote mines of Australia. A higher cab, larger radiator core and hydraulic fan drive are all part of this Australian designed package to suit our unique conditions. The C510 has become the benchmark for all heavy haul tractor units.

DEPENDABLE AND DURABLE

In true Kenworth tradition the C510 gets the job done in some of the harshest conditions the globe can deliver. Kenworth trucks are engineered and built using the best components for the long haul. Their strength, durability and reliability result in low maintenance costs and more time on the road; whilst delivering higher performance at lower costs for a longer time. High tensile steel chassis rails are straight continuous channels, custom detailed for your specification. Kenworth has engineered steel, aluminium and fibreglass into one of the lightest, toughest quality cabs built. Its riveted construction is easily repaired and it has steel reinforcements in high stress areas. Custom engineering allows each truck to be specified by the selection of best options to suit each application. Optimisation of drive train components enables higher durability and lower fuel consumption within the appropriate operating constraints.

SUPREME DRIVER COMFORT

In a Kenworth, drivers can meet demanding performance levels with the highest standards of comfort. Kenworth cabs and sleeper boxes are ergonomically designed with the professional driver in mind. Heavy duty closed cell insulation throughout the cab minimises road noise. All controls, switches and instruments fall easily to hand or eye, optimising driver concentration and minimising fatigue. Kenworth's comfortable, roomy, easily maintained driver environment combined with a high level of standard equipment and extensive options, means the best in driver performance is comfortably achieved.

SURE FOOTED AGILITY

Australian design and manufacturing, high quality materials, and Kenworth's engineering expertise place the Kenworth C5 Series trucks at the head of the field. The front axle is set forward, with integral power steering mounted ahead allowing maximum steering angles, and better weight distribution, on or off-road. The agility and strength of the C510 has been demonstrated repeatedly throughout Australia in some of the toughest and most testing environments ever experienced.

MAIN SPECIFICATIONS AT A GLANCE

CONFIGURATION	6X4
ENGINE	CUMMINS QSK19 LITRE 605 LTA 605HP AND 1950 LBFT TORQUE
TRANSMISSION	EATON RTLO221918B
STEER AXLE	MERITOR FL941
DRIVE AXLE	AXLETECH SPRC1927
REAR SUSPENSION	HENDRICKSON R1000
TYRES	MICHELIN 385/95R25
RIMS	TITAN 10 X 25

CONFIGURATION	8X6
ENGINE	CUMMINS QSK19 LITRE 605 LTA 605HP AND 1950 LBFT TORQUE
TRANSMISSION	EATON RTLO221918B
STEER AXLE	MERITOR FL941
DRIVE AXLE	SISU FR3P-48
REAR SUSPENSION	NEWAY AD390-10
TYRES	BRIDGESTONE 315/80 R22.5
RIMS	TITAN 9.00 X 22.5



One tough resource for mining.

C510 6x4

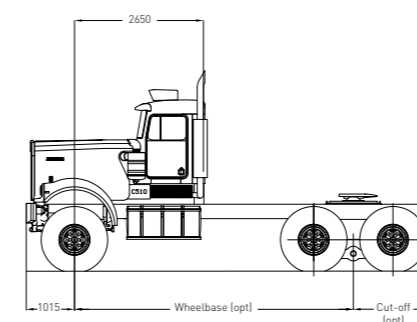

C510 8x6

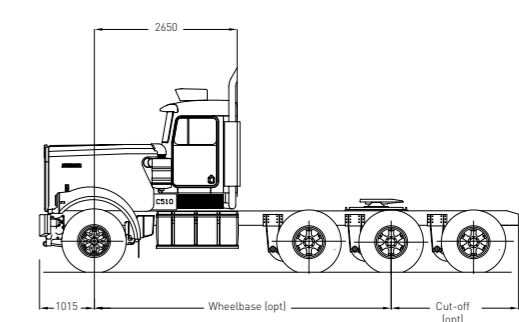

DEFINING THE BEST DEALER NETWORK

THE BEST DEALER NETWORK

Kenworth has built an extensive truck dealer network across Australia that is renowned for its professionalism and excellence in the heavy duty truck industry. The Kenworth dealer network also includes highly qualified dealers in New Zealand and Papua New Guinea.

PACCAR AUSTRALIA

Kenworth trucks are designed and manufactured in Australia to perform in some of the toughest and most demanding applications found anywhere in the world. They are application engineered to exacting standards, using the best technology and componentry.

Kenworth, a division of PACCAR Australia, is market leader in heavy duty trucks in Australia, and exports trucks to Papua New Guinea and New Zealand. PACCAR Australia also imports the DAF range of trucks from Europe and supports both Kenworth and DAF product ranges with the extensive AllRig parts and service network, and finance through PACCAR Financial.

From its beginning in Bayswater, Victoria in 1971, Kenworth's Australian operations have developed into a world class design, development, manufacturing and testing facility incorporating advanced training services.

PACCAR Australia follows a wide range of environmentally focused policies, procedures and controls and was awarded ISO 14001:2004 certification for its Kenworth manufacturing operation in 2007.

With over 45,000 Australian made trucks delivered, Kenworth Australia provides products and services to the transport sector that are the envy of the industry worldwide.

On a whole-of-life cost basis, there are few trucks that can approach a Kenworth in helping to produce a better bottom line for your business.

PACCAR INC

PACCAR Inc, a Six Sigma company, is a global technology leader in the design, manufacture and customer support of high-quality light-, medium- and heavy-duty trucks under the Kenworth, Peterbilt and DAF nameplates. There are now over 1.5 million PACCAR commercial vehicles in service worldwide. It also provides financial services and information technology and distributes truck parts related to its principal business.

